

Power Plant Design Using Gas Produced By Waste Leachate Treatment Plant

Rashidi, Zh.^{1*}, Karbassi, A. R.², Ataei, A.¹, Ifaei, P.³, Samiee-Zafarghandi, R.²
and Mohammadzadeh, M. J.⁴

¹Department of Environment and Energy, Science and Research Branch, Islamic Azad University, Tehran, Iran

²Graduate Faculty of Environment, University of Tehran, P.O.Box 14155-6135, Tehran, Iran

³Faculty of Water Engineering, Department of Civil Engineering, University of Tabriz, Tabriz, Iran

⁴Department of Environment, Pardisan Park, Tehran, Iran

Received 12 March 2012;

Revised 15 May 2012;

Accepted 9 June 2012

ABSTRACT:7500 tons of municipal solid waste produced in Tehran city is land-filled in Kahrizak disposal site. The leachate of the waste has created a lake with 180000m³ in volume. A plant is under construction to treat the leachate. A significant amount of biogas can be produced in anaerobic digestion phase in the treatment plant reactor. The designing process of a power plant in accordance with the produced biogas has been discussed in the present study. In the present investigation the air pollution from power plant has also been modeled. The leachate organic load (BOD=34400 mg/L and COD=53900 mg/L) is considerably higher when compared with other countries due to higher amount of organics available in Tehran wastes. The results indicate that an amount of 33504 m³/d biogas can be produced in Tehran's landfill that eventually would be sufficient to run a power plant of 3.4 MW capacities. The plant which is designed by Thermoflow software is consisted of two gas turbine units with 2 MW capacities so that the total capacity is 4MW. About 10% of the generated power is for in-plant consumption and the rest can be sold. The results of the air pollution modeling using Screen 3 software reveal that CO and PM amounts are in allowed range but N₂O exceeds the standard limits. The high temperature of the outlet gases emitted from gas turbines makes it possible to warm up water and regulate the anaerobic reactors temperature.

Key words: Environment, Pollution, Electricity, Waste, Leachate, Landfill

INTRODUCTION

There is a per capita energy decrease due to the cumulative population growth in the last decades and conventional energy resources restrictions. Meanwhile the rapid development of industry and technology along with the sever tendency to urbanization have increased energy requirement in societies. Environmental damages caused by indiscriminate use of fossil fuels should be added to these problems. Thus energy management has become one of the major concerns of governments and politicians. One of the best available alternatives to face the energy and environment dilemma is to tend clean (renewable) energies. Urban population growth and industrialization cause municipal and industrial waste production with an increasing rate besides the serious energy requirement. For instance, in Norway and USA, between 1992 and 1996 waste production rate showed an increasing rate equal to 3% and 4.5% per year

respectively (Renou, *et al.*, 2008). The statistics indicate that waste production rate has increased by 7.3% in Iran between 2002 and 2009 so that the average waste production was about 746 gr per person per day in 2006. There are three available approaches in order to dispose waste with energy generation recommendation: incinerating, sanitary landfilling and composting. Landfilling is the most common approach to dispose waste (Williams, 2005). Economically, the acceptable method for MSW disposal has been landfilling (Safari *et al.*, 2011). That can be a serious threat for surface and ground waters itself (Maqbool *et al.*, 2011) however technical landfilling solves the problem of pollution penetration into water by using impermeable linings, coatings and leachate collecting systems. Leachate is a high-strength wastewater that is formed due to solid waste moisture and percolation of rainwater through landfills (Hesar *et al.*, 2009). The collected leachate needs to be treated for high potential

*Corresponding author E-mail: zhowun_ra@hotmail.com

of methane emission because methane gas greenhouse effect is 21 times than the same volume of CO₂ (IPCC). On the other hand methane is supposed to be a suitable energy resource having a great heating value. Various methods are used to treat leachate; physical, chemical and biological. Biological process is more suitable than physicochemical (Marttinen *et al.*, 2002). Biological treatment includes two aerobic and anaerobic phases. Produced biogas amount is larger in anaerobic process. The most suitable alternative to treat wastewater is to apply anaerobic digesters (Rajesh Van *et al.*, 2000). This process is very effective to control greenhouse gases (Alayon *et al.*, 2001) because more methane is produced which is converted to more CO₂ while energy production process. Fast execution is one of the advantages of anaerobic digestion (Alayon *et al.*, 2001). As mentioned above, anaerobic digesters produce the most methane volume in addition to the least amount of sulfur and volatile organic compounds. In an anaerobic digester reactor, a kind of biogas is produced which is mainly composed of methane (50-65%) while COD removal process. The most important advantages of anaerobic bioreactor include its ability to separate acidogenesis and Methanogenesis (Barber and Stuckey, 1999; Vossoughi *et al.*, 2003), and to act as a two-phase system that can increase acidogenic and methanogenic activities (Barber and Stuckey, 1999). The amount of methane produced in an anaerobic digester reactor depends on COD removal efficiency, leachate origin, initial waste analysis, leachate solid material combination, leachate age, temperature and other factors. Methane production rate of a certain type of leachate is between 0.23-0.37 m³ per one kilogram of COD removal in 35°C (Garcia *et al.*, 1996). This amount is 0.4 liter per one gram of COD removal in Kahrizak. In other researches biogas and methane production rates for one gram of COD removal have been respectively reported as 496 and 377 ml on average. During methane production, harmful gases like H₂S are also produced which decline the biogas quality. Generally, biogas is composed of 40-75% methane, 15-60% CO₂ and also trace elements like 5-10% water, 0.005-2% hydrogen sulfide, 0-1% oxygen and 1% CO (Ryckebosch *et al.*, 2011). If biogas amount is more than 45%, the biogas will be flammable and considered as a renewable energy resource to generate power. Biogas composition with more than 60% methane will be like natural gas so it can be used in known power generating technologies which use natural gas. However it is better the biogas to be desulfurized and dehydrated before deployment. The storage and transportation of biogas are also economical and their handling appears to be less hazardous than fossil fuels (Nwabanne *et al.*, 2009).

Brighton, Otto and Diesel cycles are the plant cycles used in this case. Feasible engines equipment used to generate power from biogas include gas turbines, vapor turbines, reciprocating engines like spark ignition engines (SI) and combustion ignition engines (CI), micro turbines and fuel cells. SI engines which are used to generate power from several kilowatts to 5 megawatts are very sensitive to their fuel. Note that H₂S levels should not surpass the permitted range (500-700 ppm) for use in conventional internal combustion engines (Haren and Flaming, 2005). Gas turbines are more appropriate to generate power from biogas in several megawatts scale however the main problem is that altitude increase results in efficiency decrease. The population is about 12 million in Tehran city where 7500 tons MSW is produced. Kahrizak disposal site is located 25 kilometers from Tehran in Aradkooch district. The disposal age is almost 40 years in Kahrizak. There is a lake of leachate with 180000 m³ volume as a result of waste management system weakness. The lake contains organic and inorganic pollutant materials that can infiltrate into groundwater and become an environmental threat contaminating soil and water. Kahrizak leachate treatment plant is under construction to overcome the problem. The plant is supposed to be the largest in the Middle East with an area of 2 hectares upon completion. The daily treatment capacity of the designed plant is 1400 m³ of leachate and the biogas will be produced in anaerobic units.

The purpose of the present study is to estimate the amount of biogas that can be produced from anaerobic units of Kahrizak leachate treatment plant and to evaluate the feasibility of electrical power generation from the biogas. Eventually a plant will be designed corresponding the amount and quality of the produced biogas.

MATERIALS & METHODS

Kahrizak leachate treatment plant contains two hybrid anaerobic baffled reactors. The leachate enters the reactors after getting cleaned mechanically and manually by bar screens. The reactors operate at 35°C, Hydraulic Retention Time is 3.7 days and they have been designed for 75% COD removal efficiency. Reduction of temperature is very effective on COD removal efficiency (Abdoli, *et al.*, 2012).

In order to estimate the potential of biogas production of MSW leachate at anaerobic units, the characteristics of fresh leachate were measured according to the Standard Methods (APHA, 2005). The amount of biogas that can be generated was estimated using mass balance conversion of COD to methane gas (Metcalf and Eddy, 2003).

$$COD_{in} (g/d) = (COD_{in} (g/m^3))(Q) \quad \text{Eq(1)}$$

$$COD_{eff} (g/d) = (1 - RE/100)Q \quad \text{Eq(2)}$$

$$COD_{vss} (g/d) = \left(1.42 \frac{gCOD}{gVSS}\right) \times \left(0.04 \frac{gVSS}{gCOD}\right) \left(1 - \frac{RE}{100}\right) (COD_{in}) \quad \text{Eq(3)}$$

$$COD_{methane} (g/d) = COD_{in} - COD_{vss} - COD_{eff} \quad \text{Eq(4)}$$

$$CH_4 (m^3/d) = (COD_{methane}) (0.00035) \quad \text{Eq(5)}$$

Then the generated power was measured according to the produced biogas amount.

$$P = \frac{n(m^3) \times x_{CH_4} \times \eta_{engine} \times 36(MJ/m^3)}{3.6} \quad (6)$$

Where P=the potential of producing electrical power in kWh, x_{CH_4} = methane molar fraction in biogas and

η_{engine} = engine efficiency.

A plant was designed using Thermoflow software according to the quality of final biogas and the amount of the measured power. All the components of the plant were placed and their characteristics were determined. The required data of Thermoflow software as follow:

Methane share of the inlet biogas = 58%

Ambient temperature = 18°C

Atmosphere pressure = 1 bar

Inlet gas temperature = 25°C

The amount of polluting gases emitted out of the plant in addition to their emission quality was modeled using Screen 3 software. Distances where each of the pollutants reaches the highest rate, can be determined using this software.

RESULTS & DISCUSSION

Since 68.81% of solid waste is consisted of biodegradable materials according to Tehran waste analysis, leachate production potential is high in the landfill site. On the other hand, the waste is composed of high volumes of organic and biodegradable materials so leachate organic load will be high (Abdoli, et al., 2012). Kahrizak waste chemical formula is found as:

$C_{555.8}H_{856}O_{15.95}$. Leachate characteristics as follow:

COD=53900 mg/L

BOD=34400 mg/L

PH=6.8

Biogas production efficiency in an anaerobic digester reactor is affected by inlet materials. The solid waste leachate chemical formula is found as: $C_{23}H_{43.37}O_{6.8}NS_{0.29}$. The leachate and water chemical reaction with anaerobic conditions results in water, NH₃ and H₂S. The amounts of produced methane and CO₂ are found to be respectively 14.77 and 10.23 moles per one mole of above-mentioned compound according to the equilibrium. There is a trace of H₂S which owns just a little amount of products.

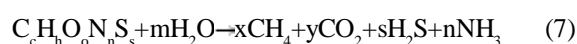

The molar fraction of methane in outlet biogas of anaerobic digester reactors is estimated to be 58%.

As mentioned above biogas production rate can be measured using mass equilibrium (Metcalf and Eddy, 2003). Considering that input COD organic load is found as: COD_{in}=53900 mg/L, inlet flow rate in the reactor (Q_a) is equal to 1400 m³/d, COD removal efficiency (RE) is equal to 75% in this case and suspended solid materials density (VSS) is equal to 150 g/m³ the produced methane rate is calculated as 19433 m³/d using equations (1) to (5) in other words 37 cubic meters of methane are obtained per each cubic meter of leachate. On the other hand, methane mole percent in biogas is equal to 58% so the produced biogas rate would be obtained as 33504 m³/d. the generated power per one cubic meter of biogas can be obtained using equation (6) production efficiency has been assumed 40% on average in the present study so the generated power is equal to 2.4 kWh in each cubic meter of biogas. It can be concluded that available electrical power to be generated consuming 33504 m³/d biogas with 58% methane is about 3.4 MW. The capacity was presumed to be 15% more than the real amount of the power to be generated in order to design a plant which is capable of generating such amount of power for a long period of time. Gas turbine cycle was used in the plant. As mentioned, gas turbine efficiency decreases by the increase of altitude. There is about 5% decrease in gas turbine efficiency according to the temperature and altitude of Kahrizak district. Thus design capacity was presumed to be 4 MW which was divided into two 2MW units. The whole designing process was performed by Thermoflow software which is illustrated schematically in fig. 1. Gas turbine properties are summarized in Table 1. The outlet gases were used as a thermal energy source because the outlet gases temperature emitting out of gas turbine is

Table1. Parameter quantities op designed gas turbine

PARAMETERS	QUANTITIES	UNITS
Gas turbine (GT PRO) (6)-GE 5371 PA		
Number of units	1	
Number units in operation	1	
Site performance		
GT lowed as percent of rating	7.789	%
Compressor pressure ratio	6.624	
Turbine exhaust temperature	276.5	C
Turbine exhaust flow	364.1	t/h
GT LHV heat rate at generator terminal	54370	kJ/kWh
GT HHV heat rate at generator terminal	60439	kJ/kWh
GT LHV efficiency at generator terminal	6.62	%
GT HHV efficiency at generator terminal	5.96	%
Exhaust loss (exhaust P-Pamb)	22.27	milibar
Power		
Electrical power at generator terminal	2001.9	kW
Compressor power	24175	kW
Turbine power	27201	kW
Mechanical loss	257.2	kW

high enough. Thus cold water can be warmed or converted to steam applying exhaust heat. This source can be used instead of heaters to keep reactor temperature 35°C or to warm the water which the plant staff consumes. The generated annual power amount can be calculated considering availability factor equal to 90%. So the produced power was evaluated as 3.4 MW and plant capacity was about 20% more.

It is not necessary to take account of availability factor=0.9 and efficiency decrease=0.05. Thus the plant can generate 29789 MWh power annually. If a maximum of 10% of power generation is used for in-plant consumption, the income would be 33677280000 Rls which is equal to 1683864 US\$ assuming that 1\$=20000 Rls. Plant pollutants emission was modeled using Screen 3 software. The investigated pollutants were N₂O, CO₂ and particulate matters (PM). The scattering amount was investigated in an area with a radius of 100-50000 meters from the plant at the ambient temperature of 293 K. Two scenarios were described while modeling.

The first scenario: outlet gases of gas turbine directly enter the atmosphere; considering the outlet gases temperature equal to 550K, maximum concentration of N₂O, CO and PM would be respectively 0.33, 0.030 and 0.033 μg/m³. The results are illustrated in figs 2 and 4.

The second scenario: outlet gases of the gas turbine enter a gas-water heat exchanger at first and the water gets warm by the available heat. The temperature of outlet gases is much lower than the first scenario (440 K). The results of modeling are illustrated in figs 5 and 7 as can be seen, the concentrations of N₂O, CO and PM pollutants in the atmosphere are respectively 0.44, 0.4 and 0.045 μg/m³. Critical points, the distances from the plant where the most amounts of pollutants are emitted, are determined using pollutants emission model. The critical distance of the first and second scenarios is respectively estimated as 10640 and 13340 m.

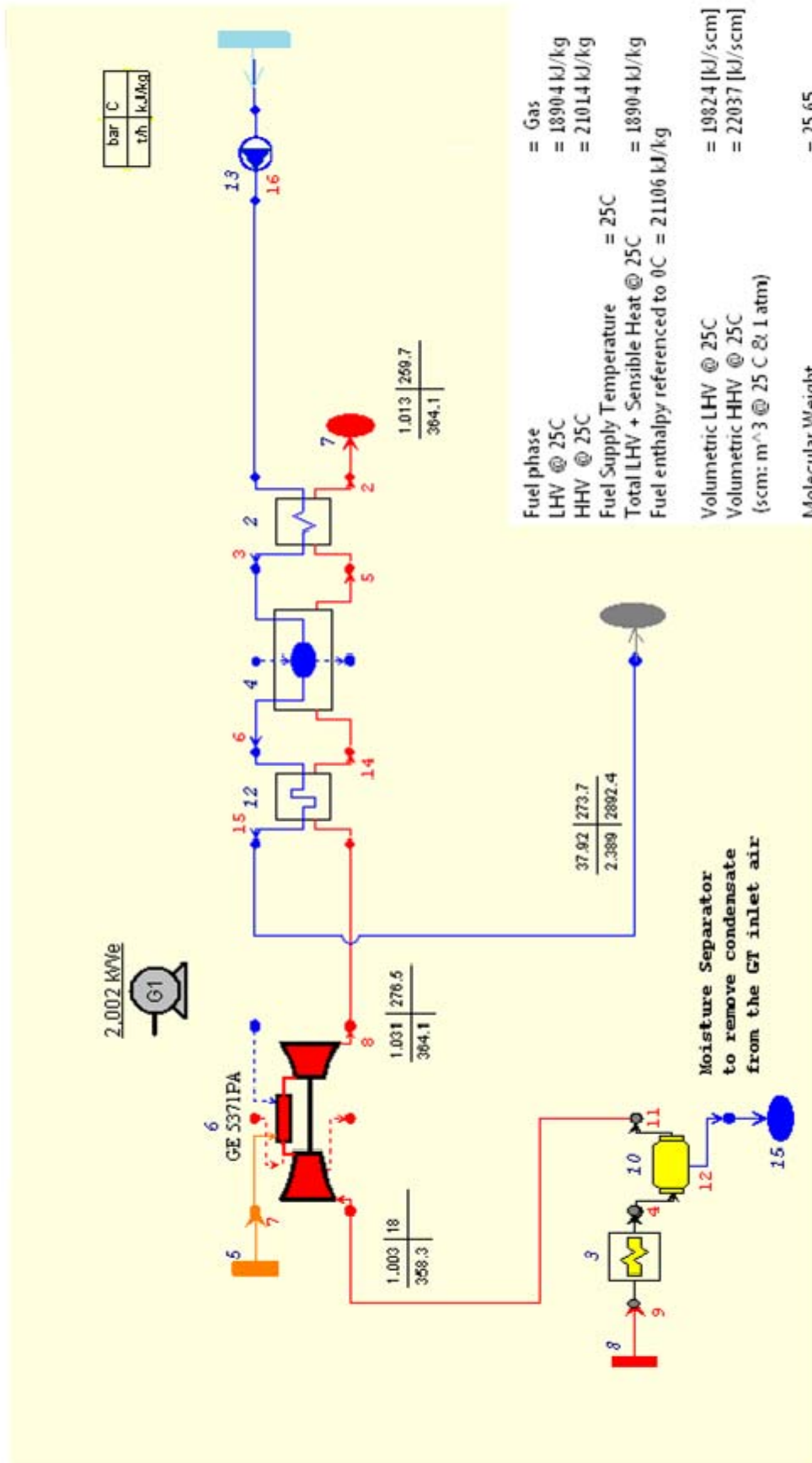

Fig. 1. schematic of designed plant

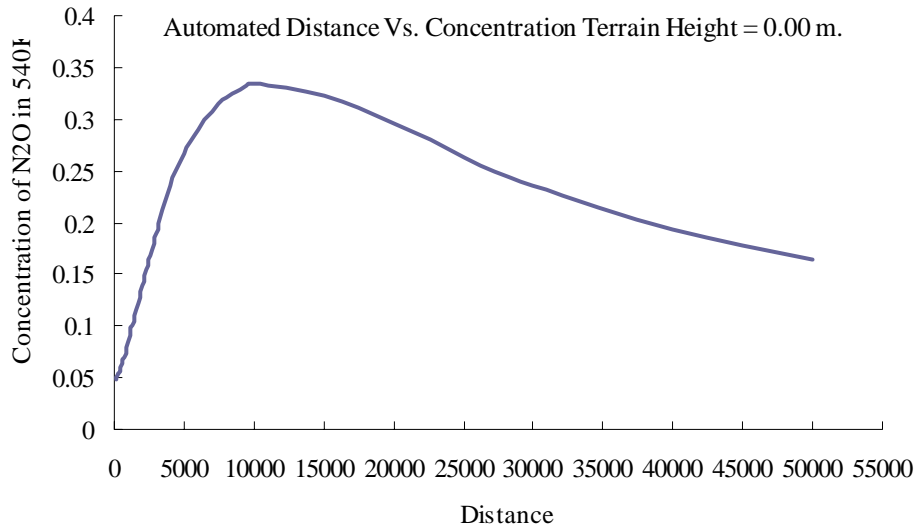

Fig. 2. Concentration of N₂O in the first scenario

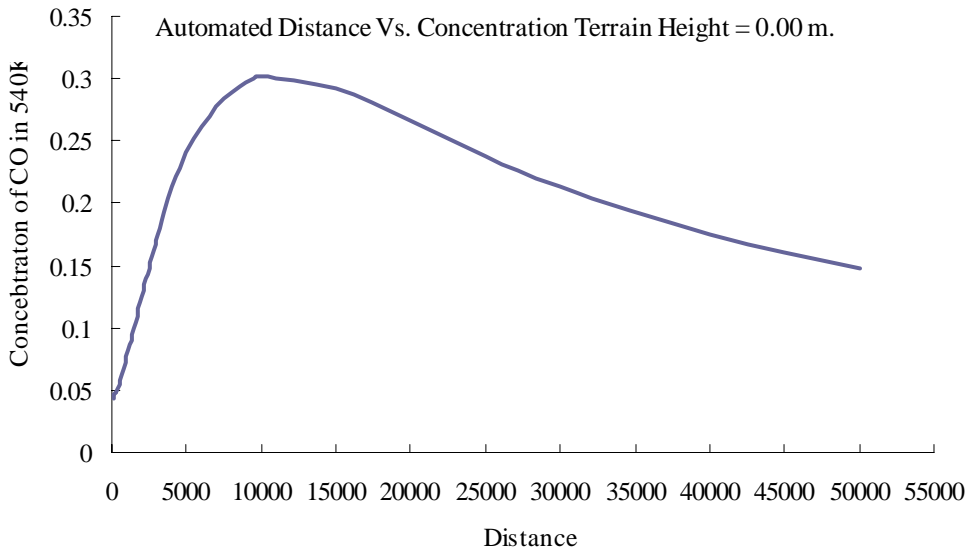

Fig. 3. Concentration of CO in the first scenario

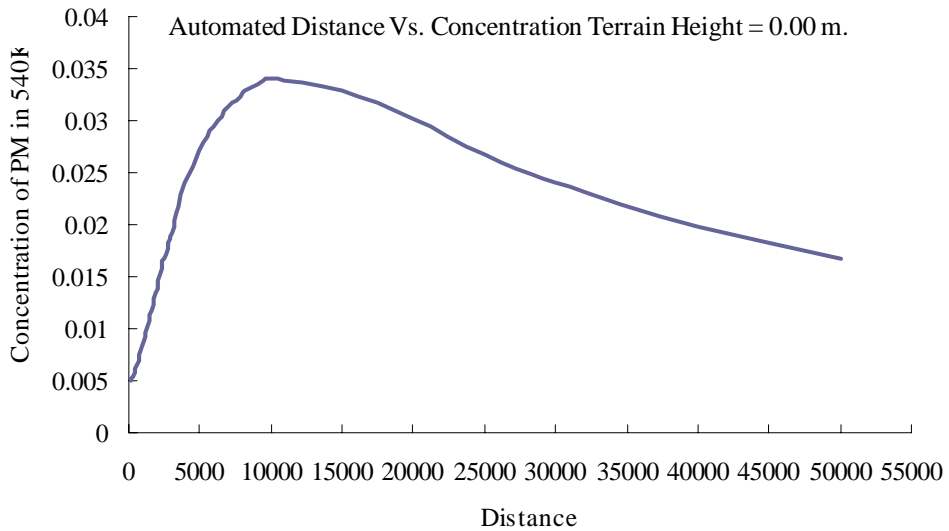

Fig. 4. Concentration of PM in the first scenario

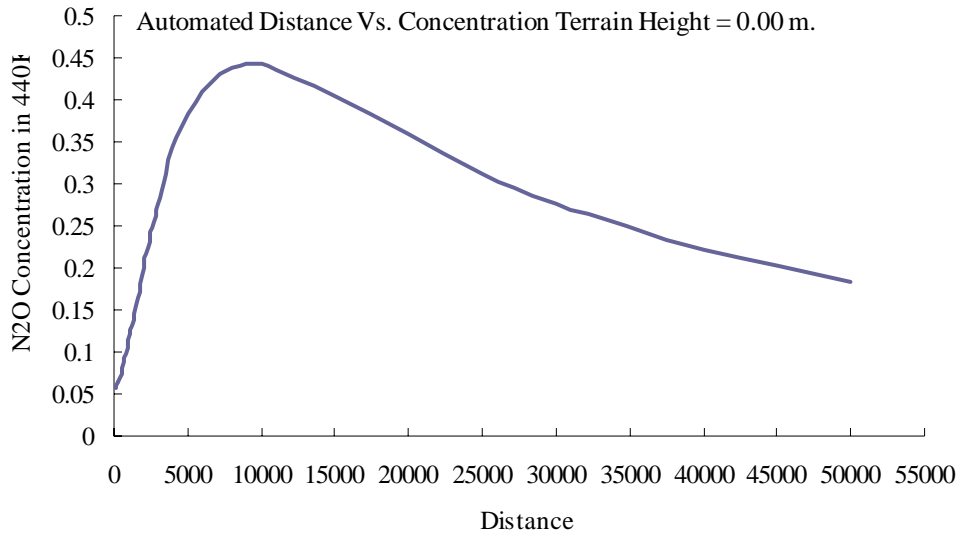

Fig. 5. Concentration of N₂O in the second scenario

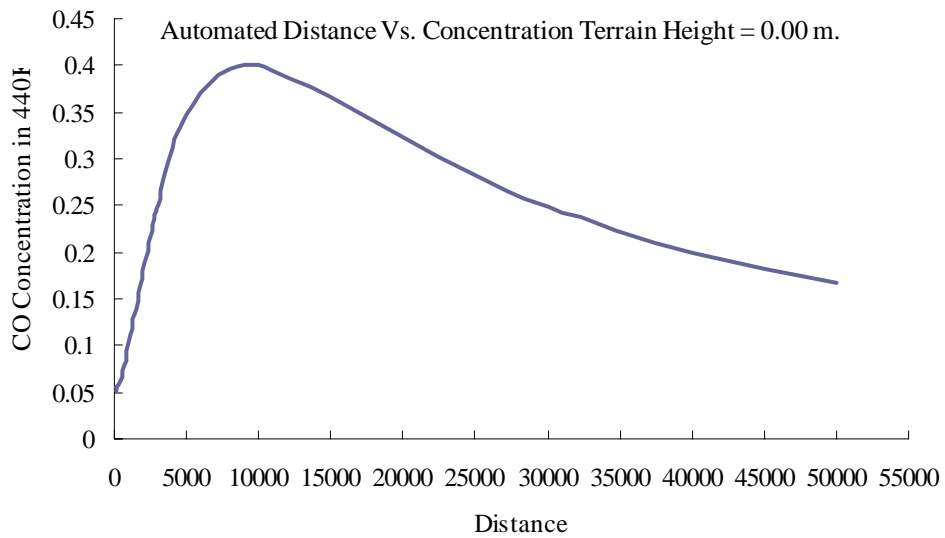

Fig. 6. Concentration of CO in the second scenario

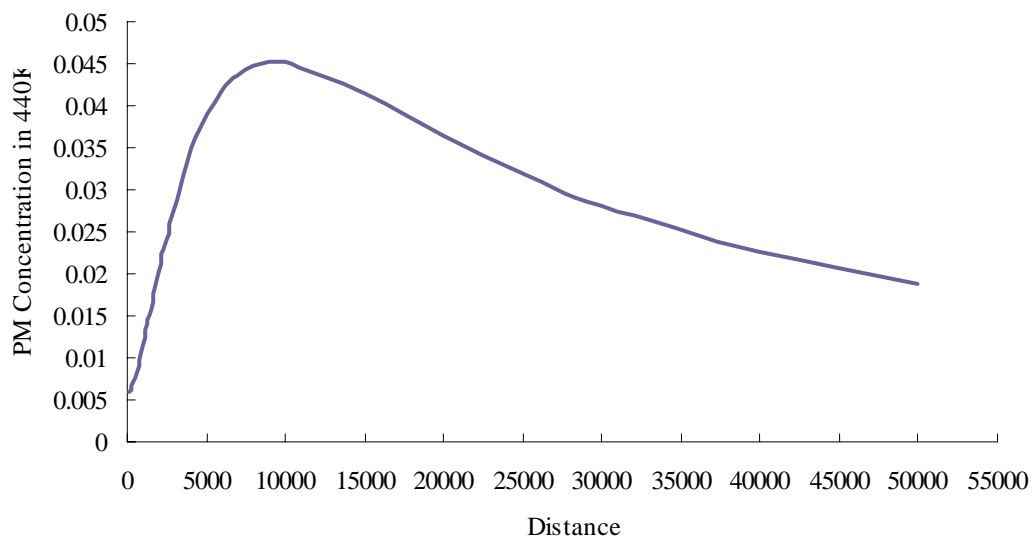

Fig. 7. Concentration of PM in the second scenario

CONCLUSION

The biogas collected in Kahrizak leachate treatment contains 58% methane according to the results obtained from the calculations. Moreover methane volume produced in the anaerobic digester reactor is 37 m³ per one cubic meter of leachate. Since the inlet leachate rate is 1400 m³/d, the produced biogas and methane rates in the anaerobic units will be respectively 33504 and 19433 m³/d. 2.4 kWh electrical powers is generated in the plant for each cubic meter of biogas. So a plant with 4 MW capacity can be constructed which is consisted of two gas turbine units each having 2 MW capacities. Methane gas is consumed in the turbines and CO₂ is produced which decreases the greenhouse effect of the gases. The produced power in the plant is 29784*10³ kWh annually. Thermal energy due to outlet gases can be used to control the temperature in anaerobic digester reactors and also for the treatment plant staff consumption. Exhaust polluting gases emission modeling reveals that the less the temperature of the outlet gases is, the more the maximum amounts of the pollutants are and also the farther the pollutants critical point is located. Meantime the comparison between modeling results and clean climate standards indicates that emission amounts of CO and PM are in the range of clean climate conditions in Iran and comply with the standards of US environmental protection agency (EPA) however N₂O pollutant rate is more than allowed limit. Some managerial and technical approaches like decreasing the height of the stack can be used to solve the problem.

REFERENCES

- Abdoli M. A., Karbassi A. R., Samiee-Zafarghandi, R., Rashidi, Zh., Gitipour S. and Pazoki M., (2012). Electricity Generation from Leachate Treatment Plant. *Int. J. Environ. Res.*, **6(2)**, 493-498.
- Alayon O., Avninelech Y. and Shechter M., (2001). Solid waste treatment as a high-priority and low-cost alternative for greenhouse gases mitigation. *Int. j. Environmental Management*, **27(5)**, 679-704.
- APHA (2005). American Public Health Association, Inc. Standard methods for the examination of water and wastewater (21st Ed.), New York, USA.
- Barber, W. P. and Stuckey D. C., (1999). The use of the anaerobic baffled reactor (ABR) for wastewater treatment: a review. *Water Research*, **33(7)**, 1559-1578.
- EPA, (2008). Catalog of CHP Technologies. U.S. Environmental Protection Agency, Combined Heat and Power Partnership.
- Garcia H., Rico J. and Garcia P.A., (1996). Comparison of anaerobic treatment of leachate from urban solid waste landfill at ambient temperature and at 35°C. *int. j. Bioresource Technology*, **58(3)**, 273-277.
- Haren M.V. and Fleming R. (2005). Electricity and heat production using biogas from the anaerobic digestion of livestock manure-literature review. University of Guelph.
- Hasar H., Unsal S.A., Ipek U., Cinar O., Yaman C., and Kinaci C., (2009). Tripping, flocculation, membrane bioreactor, reverse osmosis treatment of municipal landfill leachate. *J. Hazardous Materials*, **171(1-3)**, 309-317.
- Maqbool F., Bhatti Z.A., Malik A.H., Pervez A. and Mahmood Q., (2011). Effect of landfill leachate on the streamwater quality. *Int. J. Environ. Res.*, **5(2)**, 491-500.
- Martinen S.K., Kettunen R.H., Sormunen K.M., Soimasuo R.M. and Rintala J.A., (2001). Screening of physical-chemical methods for removal of organic material, nitrogen and toxicity from low strength landfill leachates. *Chemosphere*, **46(6)**, 851-858.
- McCarty, P. L. (1981). One hundred years of anaerobic treatment digestion. *J. Anaerobic Digestion*, **1**, 3-21.
- Metcalf and Eddy (2003). *Wastewater engineering treatment and reuse*. New York.
- Nwabanne J.T., Onukwuli O.D. and Ifeakandu C.M., (2009). Biokinetics of anaerobic digestion of municipal waste. *Int. J. Environ. Res.*, **3(4)**, 511-516.
- Rajeshwari K.V., Balakrishnan M., Kansal A., and Kishore V.V.N. (2000). State of the art of anaerobic digestion technology for industrial wastewater treatment. *Renewable and Sustainable Energy Reviews*, **4(2)**, 135-156.
- Renou S., Givaudan J.G., Poulain S., Dirassouyan F. and Moulin P., (2007). Landfill leachate treatment: Review and opportunity. *Journal of Hazardous Materials*, **150(3)**, 468-493.
- Ryckeboosch E., Drouillon M. and Vervaeren H., (2011). Techniques for transformation of biogas to biomethane. *Biomass and Bioenergy* **35(5)**, 1633-1645.
- Safari E., Jalili Ghazizade M., Shoukouh A. and Nabi Bidhendi Gh. R., (2011). Anaerobic removal of COD from high strength fresh and partially stabilized leachates and application of multi stage kinetic model. *Int. J. Environ. Res.*, **5(2)**, 255-270.
- Tehran Organization of Waste Recycling and Composting, (2008).
- Themelis N.J. and Ulloa P.A. (2007). Methane generation in landfills. *Renewable Energy*, **32(7)**, 1243-1257.
- Vossoughi M., Shakeri M. and Alemzadeh I., (2003). Performance of anaerobic baffled reactor treating synthetic wastewater influenced by decrease in COD/SO₄ ratios. *Chemical Engineering and Processing*, **42**, 811-816.
- Williams, P.T. (2005) *Waste Treatment and Disposal Second Edition*. U.K. John Wiley & Sons.